

Pressure reducing valves reduce a high and frequently fluctuating pressure to an adjustable constant pressure downstream of the valve. A spring keeps the valve open and this closes as the outlet pressure rises.

Selecting valve type and nominal diameter

Using your maximum operating data and the smallest differential pressure Δp , you should calculate the characteristic performance figure K_v (see leaflet Calculation of Pressure Regulators). Select a valve whose K_{vs} value is 30% greater than the calculated K_v figure. Additional allowances must be made for high-viscosity liquids or liquids which vaporise when depressurised.

You should also note the reduction ratio i.e. inlet pressure p_1 divided by outlet pressure p_2 . The inlet pressure acting on the cone causes the valve to open whereas the outlet pressure acting on the diaphragm/spring system causes it to close. If the reduction ratio calculated from the operating data is greater than the quoted ratio, the valve will not close. Pressure reducing valves should not be overdimensioned. Their optimum working range is within 10% to 70% of their K_{vs} value.

Selecting rated pressure and valve material

The rated pressure must exceed the maximum system pressure, irrespective of safety allowances. Please note also the effect of the temperature (see DIN 2401).

Selecting the setting range

For good control accuracy you should select a setting range which places the required outlet pressure near its upper limit. If, for example, the controlled outlet pressure is to be 2.3 bar, you should select the 0.8 to 2.5 bar setting range, not 2 to 5 bar. If the available setting range is not wide enough you may go below the bottom limit of the setting range provided that the valve loading is kept low and a high control accuracy not required.

Selecting elastomer materials

You should select elastomers according to the operating temperature and the requirements of the medium. High-pressure gases, for example, can diffuse into the elastomer and cause damage when being depressurised.

Flow velocity

Depending on pressure drop and permitted maximum noise level, we recommend the following flow velocities:

Liquids	1	-	5	m/s
Saturated steam	10	-	40	m/s
Superheated steam	15	-	60	m/s
Gases below 2 bar	2	-	10	m/s
Gases above 2 bar	5	-	40	m/s

Sense line (control line)

You should install a sense line if the selected pressure reducer is designed for sense line operation. The sense line should be connected at a distance of not less than 10 times nominal diameter downstream of the pressure reducing valve. No isolating valves should be installed in the sense line to avoid an excessive pressure differential between valve body and diaphragm.

To attenuate any oscillations occurring in the pipeline system, the sense line may be fitted with a restrictor which must never be fully closed during operation.

In the case of steam and liquids the sense line must be installed so as to fall towards the valve. Under special operating conditions, for example intermittent operation with dry steam, a compensation vessel must be installed. The sense line must be rigid as elastic hoses can induce oscillations.

Protecting your system

To protect your system you should install a safety valve downstream of the pressure reducer to prevent the maximum permitted operating pressure (normally 1.5 x maximum set pressure) being exceeded. The safety valve operating pressure should be set approximately 40% above the maximum set pressure of the pressure reducer to avoid blow-off during slight pressure fluctuations. For example: if the pressure reducer setting range is 2 - 5 bar the safety valve operating pressure must be 1.4 x 5 bar = 7 bar.

Protecting the pressure reducing valve

To protect the pressure reducer against damage from solid particles carried in the pipeline, a strainer or filter should be fitted and serviced at regular intervals.

With steam as medium, the pressure reducer should be preceded by a water trap, which is also called steam dryer, to protect it from cavitation (see below chapter "Steam Operation").

Valve seat leakage

Pressure reducers are control valves which are not required to provide a leak-proof seal (VDI/VDE Guideline 2174). Normally pressure reducers leave the factory with perfectly leakproof valve seats. During operation, however, solid particles often cause damage and seat leakage. Any low leakage requirement must be expressly specified when ordering. Valve leakage can be considerably reduced by special measures such as lapping the valve seat, using special cone seals and increasing the control (diaphragm) surfaces.

Cut-off

For the purpose of installation, servicing and isolation of the valve, shut-off valves should be installed upstream and downstream of the pressure reducer. When closing the shut-off valves the upstream valve must always be closed first. A bypass line may be necessary to maintain emergency operation.

Stellited seat and cone

In the case of abrasive media or liquids with pressure drops (inlet pressure minus outlet pressure) of more than 25 bar the valve cone must be stellited; for pressure drops above 150 bar the seat must be stellited as well.

Leakage line

If toxic or hazardous media are used the valve must feature a sealed spring cap (including setting spindle seal) fitted with a leakage line connection. When the pressure reducer is installed on site a leakage line must be fitted capable of safely and pressureless draining the escaping medium in case the control valve should become defective.

Mounting position

For gases a pressure reducing valve can normally be fitted in horizontal pipelines with the spring cap at the bottom or at the top. Installation in vertical pipe runs is possible but can result in increased wear and loss of control accuracy owing to increased friction. In the case of liquids a pressure reducer should be installed with the spring cover at the bottom. Thus gas traps upstream of the valve are avoided which would cause the valve to oscillate. For steam a pressure reducer should likewise be installed with its spring cover at the bottom to protect the diaphragm against overheating by means of a layer of condensate.

Start-up

Pressure reducers should be started up and operated without pressure surges, if possible. A sudden operation of upstream or downstream valves should be avoided.

Steam operation

If a pressure reducer is installed in a steam plant the diaphragm water reservoir must be filled before the plant is started up. There must be no danger of overheating at the installation site caused by excessive ambient temperatures or insufficient heat dissipation. Pressure regulators must not be insulated. In some cases an insulating of the body is permitted, but only with cast bodies. Never insulate diaphragm housing, mid section and spring cap (or open springs). Overheating caused by insulating destroys the elastomere of the control unit. Many steam generators send a lot of water through the piping together with the steam. Even an initial overheating can get lost through piping heat losses, so that the steam gets "wet". A piping speed of up to 25 m/s is normal for "dry steam", whilst wet steam already has the effect of a sandblasting machine at this speed, and the condensate and/or the water droplets eat holes into pipings and valve seats. In addition, water obstructs heat transition especially in heat exchangers. To avoid it, the water should be removed by a water trap, also called steam dryer, as quickly as possible and without steam losses.

Know How Pressure Reducing Valves



Pressure reducing valves reduce a high and frequently fluctuating pressure to an adjustable constant pressure downstream of the valve. A spring keeps the valve open and this closes as the outlet pressure rises.

Setting the pressure

Pressure reducing valves are normally supplied by us with a relaxed spring. This means that a valve is set at the factory to the minimum outlet pressure. The required pressure should be set under operating conditions.

Maintenance

Pressure reducers must be cleaned and serviced regularly.

Valves free of oil and grease or silicone

Please pay attention to order an fit only spares free of oil and grease resp. free of silicone.

Recommended installation for liquids and gasses

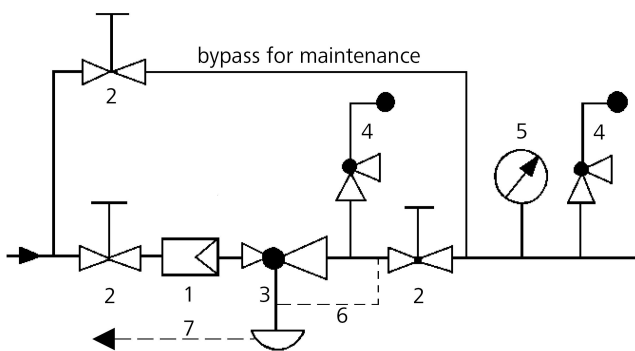

- | | | |
|-------------------------|--------------------|----------------|
| 1 Strainer
or Filter | 3 Pressure Reducer | 6 Sense Line |
| 2 Shutoff Valves | 4 Safety Valve | 7 Leakage Line |
| 5 Pressure Gauge | | |
- Sense Line Connection 10 - 20 x DN behind the valve

Recommended installation for steam

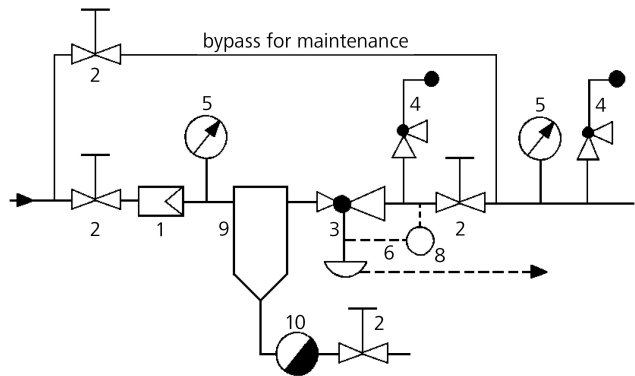

- | | | |
|--------------------|------------------|----------------|
| 1 Strainer | 5 Pressure Gauge | 9 Water Trap |
| 2 Shutoff Valves | 6 Sense Line | (Steam Dreyer) |
| 3 Pressure Reducer | 7 Leakage Line | 10 Steam Trap |
| 4 Safety Valves | 8 Expansion Tank | |
- Sense line connection 10 - 20 x DN behind the valve

Please consult our engineer if extreme operating conditions apply or whenever you are in doubt.

Notes on Safety, Operating Instruction etc. MUST be followed.